

REV. NO. 4SG6-APP

REV. LET.	REVISION RECORD	DATE	BY	CHECK'D	CHECK'D	APPR'D
△	도면 양식 변경 (신규 도면 양식 적용)	'16.04.27	K.H.Joo	<i>A. Joo</i>		<i>Y. K. Kim</i>

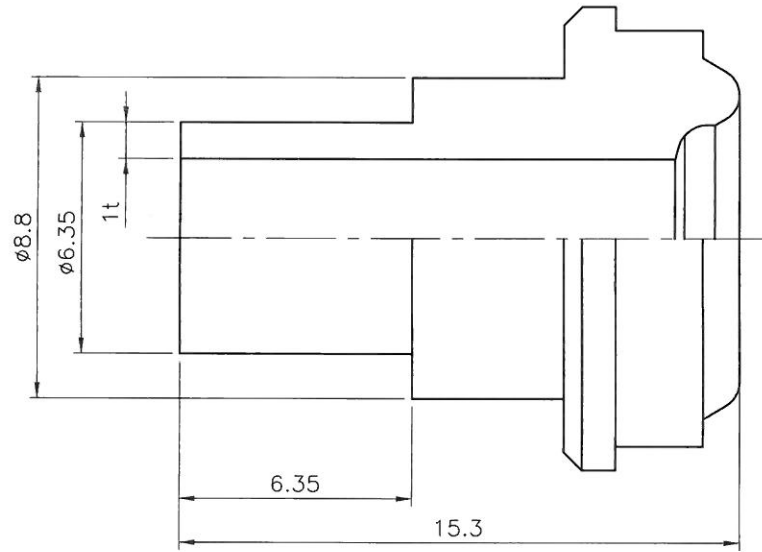

Check	Ordering Number	Body Material	Grade
	S4SG6	316L Stainless Steel	BA
	S4SG6-P	316L Stainless Steel	EP
	D4SG6	316L VAR Stainless Steel	BA
	D4SG6-PX	316L VAR Stainless Steel	EP

**TK-FUJIKIN CORPORATION**

TITLE  
METAL FACE SEAL FITTINGS  
1/4" FEMALE MICRO GLAND

DRAWN	CHECKER	CHECKER	APPR'D
<i>TKF</i> 2011.01.11 정순용	<i>TKF</i> 2011.01.12 정해용	<i>TKF</i> 2011.01.12 김홍남	<i>TKF</i> 2011.01.12 H.Hoshiyama

UNIT: mm, SCALE: NONE, SIZE: A4

"X" NUMBER: 1 OF 1, DWG. NO.: 4SG6-APP, REV. △

REV. 0 DWG. NO. 4SG6-APP

REV. LET.	REVISION RECORD	DATE	BY	CHECK'D	CHECK'D	APPR'D
△						

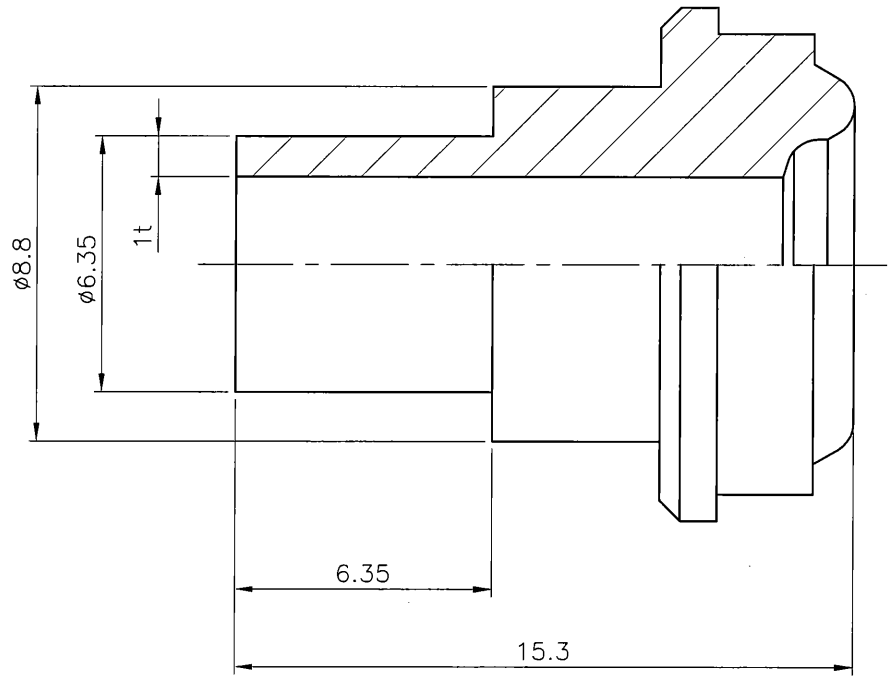

NOTE  
1. 본 도면은 승인용 도면이다.

Check	Ordering Number	Body Material	Grade
	S4SG6	SUS316L Single Melt	BA
	S4SG6-P	SUS316L Single Melt	EP
	D4SG6	SUS316L Double Melt	BA
	D4SG6-PX	SUS316L Double Melt	EP

**TKSCT corporation**

TITLE METAL FACE SEAL FITTINGS  
1/4" FEMALE MICRO GLAND

DRAWN  2011. 1. 11 정순호	CHECKED  2011. 1. 12 정해용	CHECKED  2011. 01. 12 정해용	APPR'D  2011. 1. 12 정해용
UNIT mm	SCALE 1:1	SIZE A4	

"X" NUMBER

SHT. NO. 1 OF 1 DWG. NO. 4SG6-APP REV. 0